

Features

- ▶ Sensor IC based on HALIOS® technology
- ▶ Up to 4 sending channels, 1 compensation channel and 1 differential receiver input for various HALIOS® applications
- ▶ 16 bit micro controller 'EL16' with debug interface
- ▶ Up to 1.5K x 18 (3KByte) SRAM including 2 bit parity per 16 bit word and byte write support
- ▶ Up to 30K x 22 (60KByte) FLASH including 6 bit CRC checksum per 16 bit word
- ▶ SPI and I²C communication interface
- ▶ SCI interface incl. LIN support
- ▶ Watchdog, 32 bit timer, up to 8 GPIOs
- ▶ Multiply unit
- ▶ Supply voltage range 2.25V to 2.75V
- ▶ Operating temperature range -40°C to +85°C
- ▶ QFN 5x5 32Ld package

Applications

- ▶ Optical or capacitive input devices
- ▶ Proximity and gesture detection
- ▶ Compact HMI interfaces for one-dimensional up to three-dimensional input

General Description

The IC is based on an optical bridge technology which provides a non-mechanical detection of movements.

The system detects the optical reflections of an object in front of the sensor by using a function principle called HALIOS® (High Ambient Light Independent Optical System) which is very effective in the suppression of ambient light and also has self calibration capability to eliminate disturbances caused by housing reflections and scratches.

In the same manner capacitive systems can be addressed by using the integrated charge amplifier.

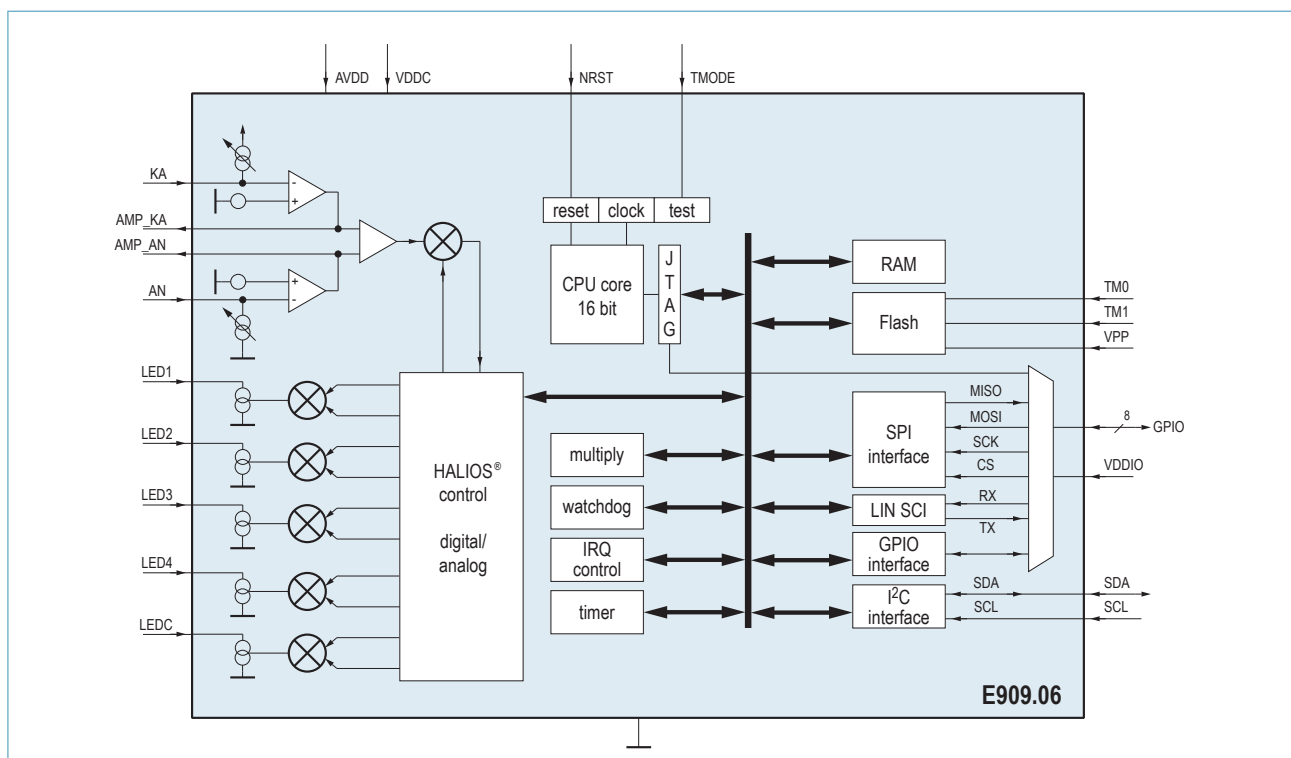

ELMOS Semiconductor AG – Headquarters

Heinrich-Hertz-Str. 1 | 44227 Dortmund | Germany

Phone +49 (0) 231-75 49-100 | Fax +49 (0) 231-75 49-149

sales@elmos.de | www.elmos.de

Note ELMOS Semiconductor AG (below ELMOS) reserves the right to make changes to the product contained in this publication without notice. ELMOS assumes no responsibility for the use of any circuits described herein, conveys no licence under any patent or other right, and makes no representation that the circuits are free of patent infringement. While the information in this publication has been checked, no responsibility, however, is assumed for inaccuracies. ELMOS does not recommend the use of any of its products in life support applications where the failure or malfunction of the product can reasonably be expected to cause failure of a life-support system or to significantly affect its safety or effectiveness. Products are not authorized for use in such applications.

Copyright © 2009 ELMOS. Reproduction, in part or whole, without the prior written consent of ELMOS, is prohibited.